

SPLIT TEST BOOTS

APT™ brand split test boots are designed to make the integrity testing of secondary contained XP Flexible Piping simple and easy. For use on both new or existing sites, these boots feature a hinged design that allows you to clamp the boot down over the pipe after it has been installed. The boot locks itself in position between the primary and secondary pipe layers using the stainless steel clamp.



HIGHLIGHTS

- The integrated Schrader valve allows you to apply air pressure (5-8 psi) while the Nitrile rubber seals create an airtight chamber for testing purposes.
- Once testing is complete the boot can be left in place for future testing or easily removed and used for testing on other sites.
- Boots can be installed during or after pipe installation.
- Boots are manufactured using fuel-resistant Nitrile rubber seals and a robust glass-filled nylon body with stainless steel valve and fittings.
- The O-ring hinge boot design provides easy, one-handed installation.
- The clamp is tightened using a ½" nut to form an airtight chamber between the primary and secondary pipe layer.
- No pipe disconnection necessary on existing lines.

SPECIFICATIONS

- Body material: Glass-filled nylon with Nitrile O-rings
- Clamp and valve material: Stainless steel
- Pressure rating: 5-8 psi
- Temperature rating: -4 °F to 100 °F

Installation

- 1 Split test boot
- 2 XP pipe (secondary layer)
- 3 XP pipe (primary layer exposed)

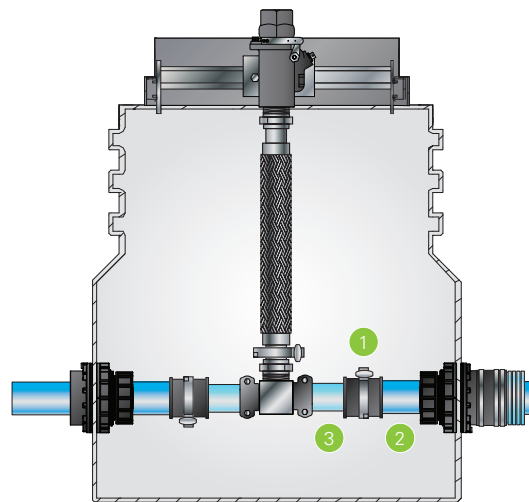

ORDERING INFORMATION

Model	Description
SPTB-150	Split test boot for XP-150-SC (1½") piping
SPTB-175	Split test boot for XP-175-SC (1¾") piping
SPTB-200	Split test boot for XP-200-SC (2") piping